

# ELETTROMANDRINI AD ALTA VELOCITA' / HIGH SPEED ELECTRO-SPINDLES

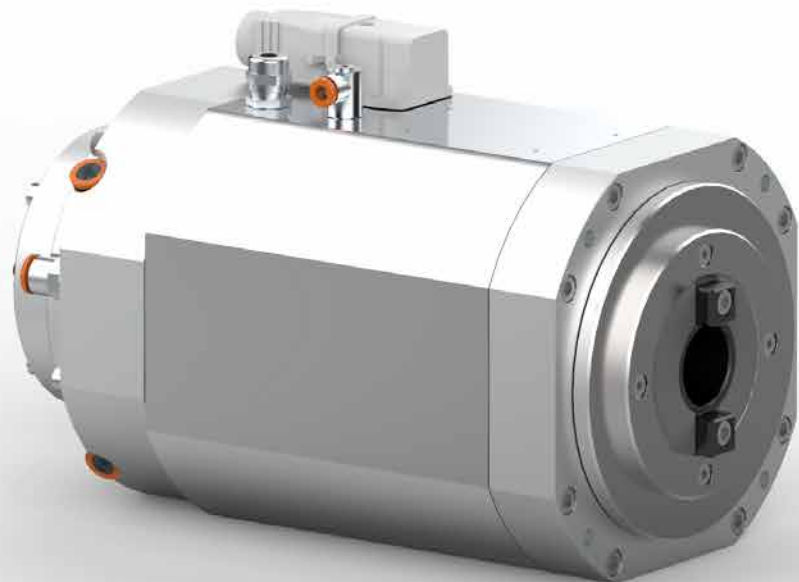

**Cono ISO 30 DIN 69873**  
ISO 30 DIN 69873 toolholder



**Classe di protezione IP55**  
IP55 degree of protection



**Raffreddamento aria compressa**  
Compressed air cooling



**Raffreddato a liquido**  
Liquid cooling



**Giunto H2O integrato "Ghost"**  
Integrated H2O joint "Ghost"



**Sensore di rilevamento acqua**  
Water leaking sensor



**SBE COMBI COMPATIBILE**  
SBE COMBI COMPATIBLE

## IMPROVE YOUR F.O.R.C.E.



**FLESSIBILITA'**  
FLEXIBILITY



**OTTIMIZZAZIONE**  
OPTIMIZATION



**RAPIDITA'**  
RAPIDITY



**COMBINAZIONE**  
COMBINATION



**EFFICIENZA**  
EFFICIENCY

# SE 150

[www.saccardo.it](http://www.saccardo.it)

MADE IN ITALY



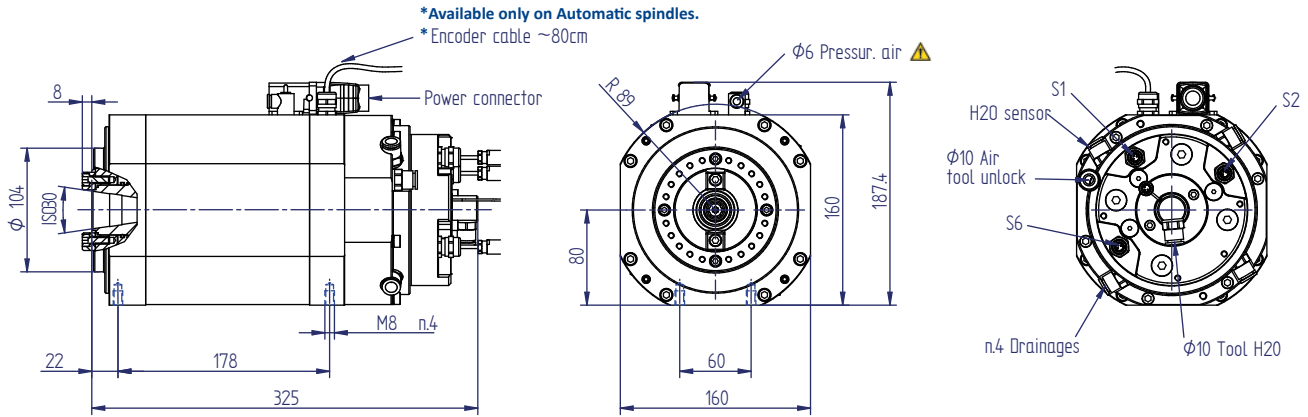

\*Available only on Automatic spindles.  
\*Encoder cable ~80cm

Use only filtered dry air.  
1-1,5 bar - 150 NI/min

SENSORI CAMBIO UTENSILE / TOOL CHANGE SENSORS		
S1= Utensile agganciato S1= Locked toolholder	S2= Utensile espulso S2= Ejected toolholder	S6= No utensile S6= No toolholder

4 POLES / 400V

Size	Duty	kW	Nm	rpm	A	Hz	Kg
A4	S1	1,0	5,5	1720	3,3	60	22
	S6-60%	1,2	6,7	1700	3,5		
B4	S1	1,7	5,6	2900	4,4	100	
	S6-60%	2,0	6,6	2880	4,8		
C4	S1	3,1	5,1	5840	6,6	200	
	S6-60%	3,6	5,9	5810	7,5		
D4	S1	4,5	4,9	8780	9,0	300	
	S6-60%	5,2	5,7	8740	10,3		

Max vel. 12000 rpm (400Hz) / Max speed 12.000 rpm (400 Hz)

SE.AA: Automatic tool change by TTL encoder  
SE.AR: Rapid tool change without encoder

Other powers or polarity on request

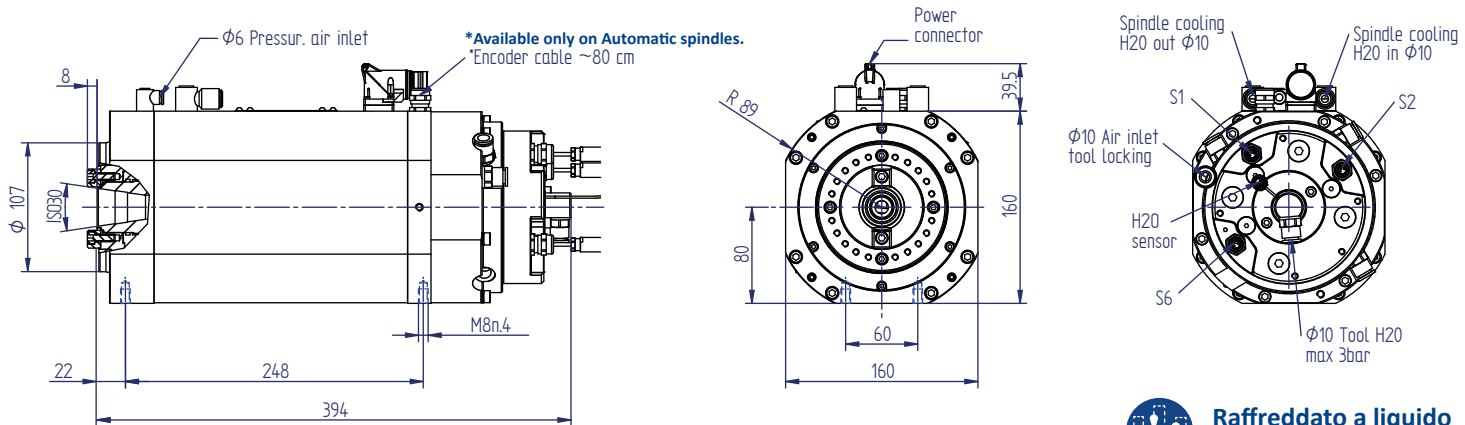

\*Available only on Automatic spindles.  
\*Encoder cable ~80 cm

4 POLES / 400V

Size	Duty	kW	Nm	rpm	A	Hz	Kg
A4	S1	2,0	11,8	1620	5,4	60	30
	S6-60%	2,4	14,8	1545	6,6		
B4	S1	3,4	11,5	2815	7,7	100	
	S6-60%	4,0	13,8	2765	9,1		
C4	S1	6,2	10,1	5850	13,6	200	
	S6-60%	7,2	11,8	5820	15,3		
D4	S1	9,0	9,7	8820	18	300	
	S6-60%	10,4	11,3	8785	20,6		

Max vel. 14000 rpm (467Hz) / Max speed 14.000 rpm (467 Hz)

Raffreddato a liquido  
Liquid cooling

The product features described in the present catalogue are approximated. Saccardo GCF S.r.l.u. reserves the right to make any modification to the components whenever deemed necessary, without prior notice, in order to enhance the product quality, based on the technical knowledge acquired and the current state of the art.

