

VDI 3425 (DIN 69880)

TOOLING SYSTEMS SPANWERKZEUGE TAKIM TUTUCU SİSTEMLERİ



Gisstec®

CONTENTS / INHALT / İÇİNDEKİLER

Radial Toolholder / Radial-Werkzeughalter Form B1-B2 Radial Kater Tutucu Form B1-B2	116
Radial Toolholder / Radial-Werkzeughalter Form B3-B4 Radial Kater Tutucu Form B3-B4	117
Axial Toolholder / Axial-Werkzeughalter Form C1-C2 Axial Kater Tutucu Form C1-C2	118
Axial Toolholder / Axial-Werkzeughalter Form C3-C4 Axial Kater Tutucu Form C3-C4	119
Boring Holder Form E1 / Bohrerhalter Form E1 Takma Uçlu U-drill Tutucu Form E1	120
Boring Bar Holder Form E2 / Bohrerhalter Form E2 Delik Kater Tutucu Form E2	121
ER Collet Chuck Form E4 / ER Spannzangenfutter Form E4 ER Pens Başlığı Form E4	122
Adaptor Sleeve / Zwischenhülse F1 Mors Konik F1	123
Drill Chuck Adaptor / Bohrfutteraufnahme Mandren Malafası	123
NC-Drill Chuck / Kurzbohrfutter NC-Mandren Malafası	124
Tapping Chuck / Gewindeschneidfutter Kılavuz Çekme Başlığı	125
Protective Plug Z2 / Schutzstopfen Z2 Plastik Kör Tapa Z2	125



Insert for Radial Toolholders left Spindle Movement

Einsatz von Radial-Werkzeughaltern bei linker Spindeldrehrichtung
Fener Milinin Sol Dönüş Yönü için Radial Tutucu

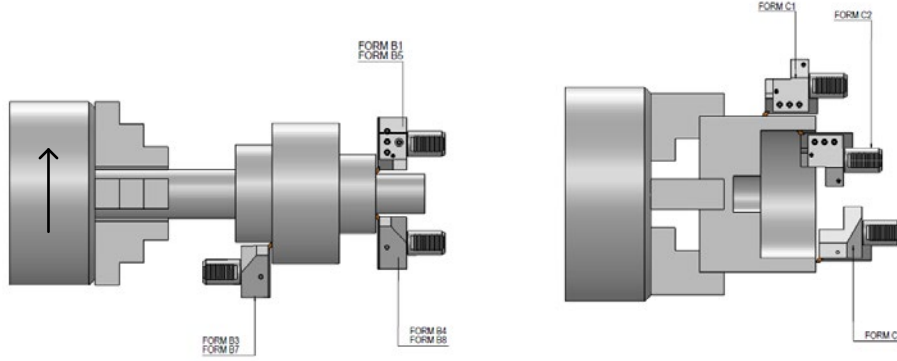

Insert for Radial Toolholders right Spindle Movement

Einsatz von Radial-Werkzeughaltern bei rechter Spindeldrehrichtung
Fener Milinin Sağ Dönüş Yönü için Radial Tutucu

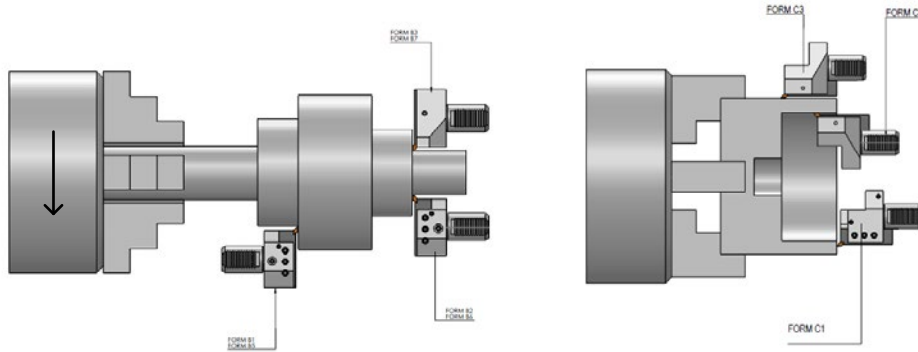

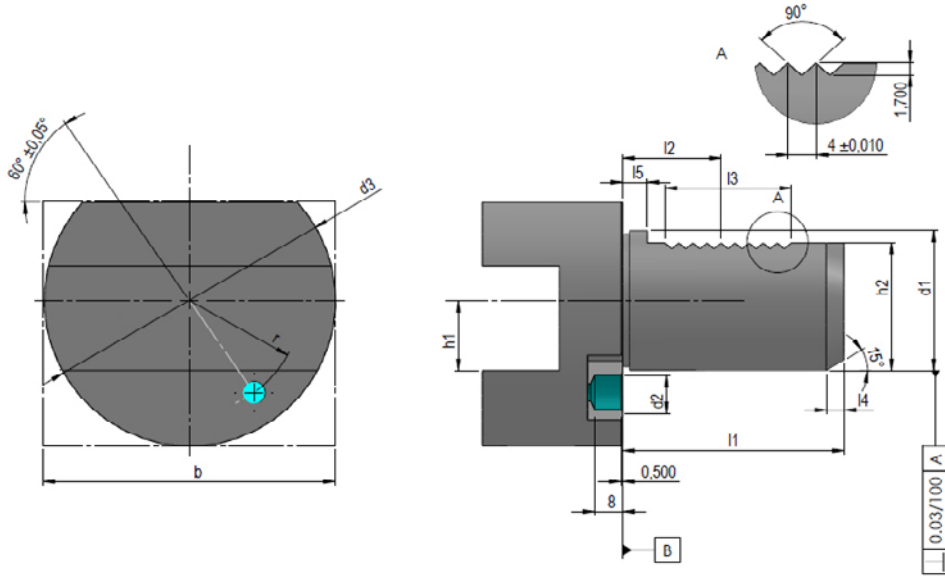

d_1	b	h1 max.	d2	d3	h2 ± 0,1	r ± 0,02	L1 max.	L2 ± 0,05	L3 max.	L4 max.	L5
16	42	12	8	40	15,0	14,5	32	12,7	16	2	3,5
20	52	16	10	50	18,0	18,0	40	21,7	24	2	7,0
25	60	16	10	58	23,5	21,0	48	21,7	24	2	7,0
30	70	20	14	68	27,0	25,0	55	29,7	40	2	7,0
40	85	25	14	83	36,0	32,0	63	29,7	40	3	7,0
50	100	32	16	98	45,0	37,0	78	35,7	48	3	8,0

Description : The tools are manufactured of hardened steel with a hardness of HRC 58 ± 2.
The shaft teeth surface and the holder are grinded.
All toolholders have a big movable coolant nozzle and a thread for external coolant.

Ausführung : Die Werkzeughalter sind aus legiertem Einsatzstahl HRC 58 ± 2 komplett brüniert und präzisionsgeschliffen.
Sämtliche Werkzeughalter haben eine große verstellbare Kugelspritzdüse und Gewindeanschluß für Rohrverschraubung, bzw. innerer Kühlmittelzufuhr.

Teknik Özelliği : Takım tutucular alaşımli çelikten yapılmaktadır. HRC 58 ± 2.
Tamamen siyahlaştırılmıştır ve hassas taşlanmıştır.
Bütün takımlarda ayarlanabilir soğutucu gözler mevcuttur.
Aynı zamanda dıştan soğutma borularının bağlantı dişleri mevcuttur.



Radial Toolholder Form B1 right, short

VDI (DIN 69880)

Radial-Werkzeughalter Form B1 rechts, kurz

Radial Kater Tutucu Form B1 sağ, kısa

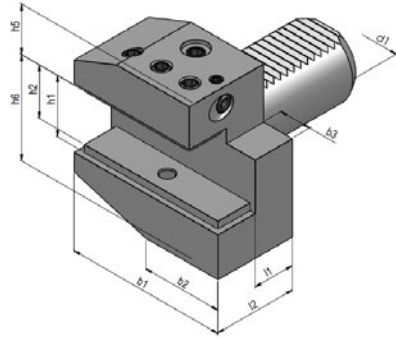

Order No. Bestell-Nr. Sipariş No.	Description Bezeichnung Açıklama	d ₁	h ₁	h ₂	l ₂	l ₁	b ₁	b ₂	b ₃	h ₅	h ₆
730.31.120	VDI30 B1 30x20	30	20	16	40	22	70	35	10	28	38
740.31.125	VDI40 B1 40x25	40	25	20	44	22	85	42,5	12,5	32,5	48

Radial Toolholder Form B2 left, short

VDI (DIN 69880)

Radial-Werkzeughalter Form B2 links, kurz

Radial Kater Tutucu Form B2 sol, kısa

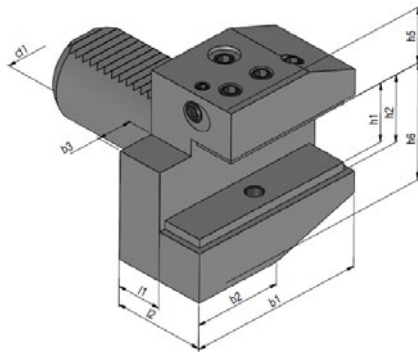

Order No. Bestell-Nr. Sipariş No.	Description Bezeichnung Açıklama	d ₁	h ₁	h ₂	l ₂	l ₁	b ₁	b ₂	b ₃	h ₅	h ₆
730.32.120	VDI30 B2 30x20	30	20	16	40	22	70	35	10	28	38
740.32.125	VDI40 B2 40x25	40	25	20	44	22	85	42,5	12,5	32,5	48

Radial Toolholder Form B3 Overhead right, short

VDI (DIN 69880)



Radial-Werkzeughalter Form B3 Überkopf rechts, kurz

Radial Kater Tutucu Form B3 Ters sağ, kısa

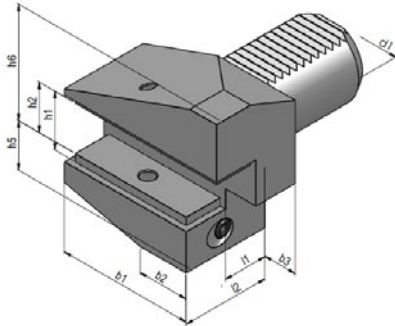

Order No. Bestell-Nr. Sipariş No.	Description Bezeichnung Açıklama	d ₁	h ₁	h ₂	l ₂	l ₁	b ₁	b ₂	b ₃	h ₅	h ₆
730.33.120	VDI30 B3 30x20	30	20	16	40	22	70	35	10	35	38
740.33.125	VDI40 B3 40x25	40	25	20	44	22	85	42,5	12,5	42,5	48

Radial Toolholder Form B4 Overhead left, short

VDI (DIN 69880)



Radial-Werkzeughalter Form B4 Überkopf links, kurz

Radial Kater Tutucu Form B4 Ters sol, kısa

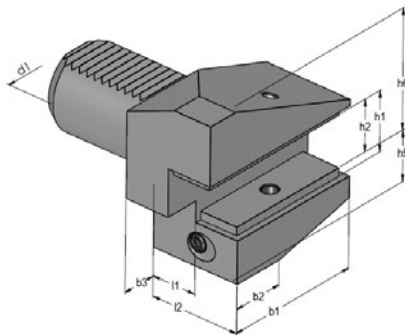

Order No. Bestell-Nr. Sipariş No.	Description Bezeichnung Açıklama	d ₁	h ₁	h ₂	l ₂	l ₁	b ₁	b ₂	b ₃	h ₅	h ₆
730.34.120	VDI30 B4 30x20	30	20	16	40	22	70	35	10	35	38
740.34.125	VDI40 B4 40x25	40	25	20	44	22	85	42,5	12,5	42,5	48

Axial Toolholder Form C1 right

VDI (DIN 69880)



Radial-Werkzeughalter Form C1 rechts

Radial Kater Tutucu Form C1 sağ

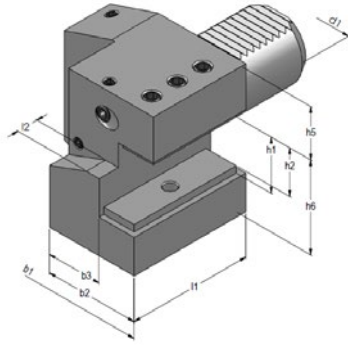

Order No. Bestell-Nr. Sipariş No.	Description Bezeichnung Açıklama	d ₁	h ₁	h ₂	b ₁	b ₂	b ₃	l ₁	l ₂	h ₅	h ₆
730.41.120	VDI30 C1 30x20	30	20	16	70	35	17	70	10	28	38
740.41.125	VDI40 C1 40x25	40	25	20	85	42,5	21	85	12,5	32,5	48

Axial Toolholder Form C2 left

VDI (DIN 69880)



Axial-Werkzeughalter Form C2 links

Axial Kater Tutucu Form C2 sol

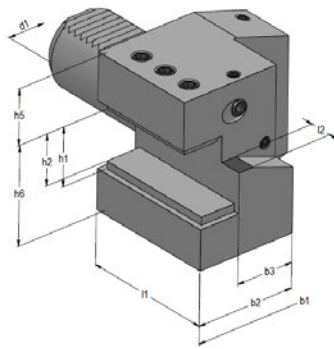

Order No. Bestell-Nr. Sipariş No.	Description Bezeichnung Açıklama	d ₁	h ₁	h ₂	b ₁	b ₂	b ₃	l ₁	l ₂	h ₅	h ₆
730.42.120	VDI30 C2 30x20	30	20	16	70	35	17	70	10	28	38
740.42.125	VDI40 C2 40x25	40	25	20	85	42,5	21	85	12,5	32,5	48

Axial Toolholder Form C3 Overhead right, short

VDI (DIN 69880)



Axial-Werkzeughalter Form C3 Überkopf rechts, kurz

Axial Kater Tutucu Form C3 Ters sağ, kısa

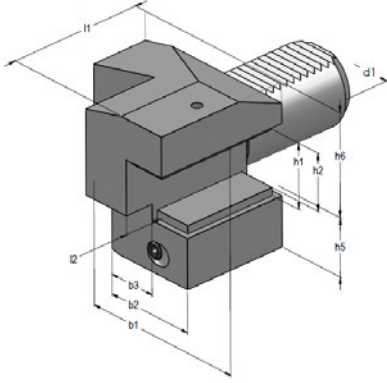

Order No. Bestell-Nr. Sipariş No.	Description Bezeichnung Açıklama	d ₁	h ₁	h ₂	b ₁	b ₂	b ₃	l ₁	l ₂	h ₅	h ₆
730.43.120	VDI30 C3 30x20	30	20	16	70	35	17	70	10	35	38
740.43.125	VDI40 C3 40x25	40	25	20	85	42,5	21	85	12,5	42,5	48

Axial Toolholder Form C4 Overhead left, short

VDI (DIN 69880)



Axial-Werkzeughalter Form C4 Überkopf links, kurz

Axial Kater Tutucu Form C4 Ters sol, kısa

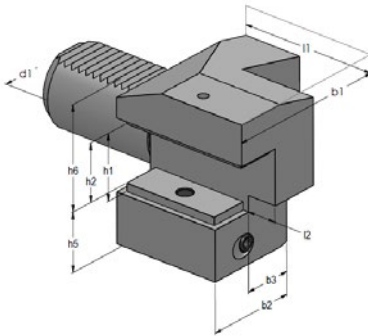

Order No. Bestell-Nr. Sipariş No.	Description Bezeichnung Açıklama	d ₁	h ₁	h ₂	b ₁	b ₂	b ₃	l ₁	l ₂	h ₅	h ₆
730.44.120	VDI30 C4 30x20	30	20	16	70	35	17	70	10	38	35
740.44.125	VDI40 C4 40x25	40	25	20	85	42,5	21	85	12,5	48	42,5

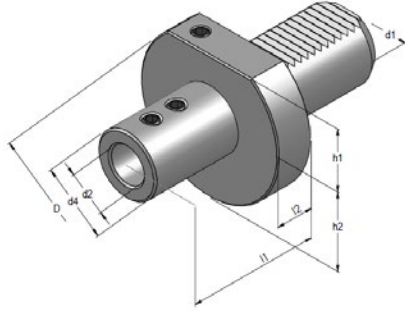

Order No. Bestell-Nr. Sipariş No.	Description Bezeichnung Açıklama	d ₁	d ₂	d ₄	D	h ₁	h ₂	l ₁	l ₂
730.51.116	VDI30 E1 30x16	30	16	36	68	28	30	64	22
730.51.120	VDI30 E1 30x20	30	20	40	68	28	30	67	22
730.51.125	VDI30 E1 30x25	30	25	45	68	28	30	71	22
730.51.132	VDI30 E1 30x32	30	32	52	68	28	30	75	22
730.51.140	VDI30 E1 30x40	30	40	60	68	28	30	95	22
740.51.116	VDI40 E1 40x16	40	16	36	83	32,5	-	64	22
740.51.120	VDI40 E1 40x20	40	20	40	83	32,5	-	67	22
740.51.125	VDI40 E1 40x25	40	25	45	83	32,5	-	75	22
740.51.132	VDI40 E1 40x32	40	32	52	83	32,5	-	75	22
740.51.140	VDI40 E1 40x40	40	40	60	83	32,5	-	90	22

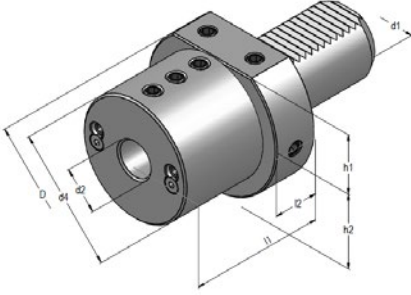

Order No. Bestell-Nr. Sipariş No.	Description Bezeichnung Açıklama	d ₁	d ₂	d ₄	D	h ₁	h ₂	l ₁	l ₂
730.52.108	VDI30 E2 30x8	30	8	68	55	28	30	60	22
730.52.110	VDI30 E2 30x10	30	10	68	55	28	30	60	22
730.52.112	VDI30 E2 30x12	30	12	68	55	28	30	60	22
730.52.116	VDI30 E2 30x16	30	16	68	55	28	30	60	22
730.52.120	VDI30 E2 30x20	30	20	68	55	28	30	60	22
730.52.125	VDI30 E2 30x25	30	25	68	55	28	30	60	22
730.52.132	VDI30 E2 30x32	30	32	68	55	28	30	75	22
740.52.108	VDI40 E2 40x8	40	8	83	55	32,5	-	75	22
740.52.110	VDI40 E2 40x10	40	10	83	55	32,5	-	75	22
740.52.112	VDI40 E2 40x12	40	12	83	55	32,5	-	75	22
740.52.116	VDI40 E2 40x16	40	16	83	55	32,5	-	75	22
740.52.120	VDI40 E2 40x20	40	20	83	55	32,5	-	75	22
740.52.125	VDI40 E2 40x25	40	25	83	55	32,5	-	75	22
740.52.132	VDI40 E2 40x32	40	32	83	55	32,5	-	75	22
740.52.140	VDI40 E2 40x40	40	40	83	55	32,5	-	90	22



Reduction Sleeve
Reduzierhülse
Kater Redüksiyonu

ER Collet Chuck Form E4

VDI (DIN 69880)

ER Spannfutter Form E4

ER Pens Başlığı Form E4

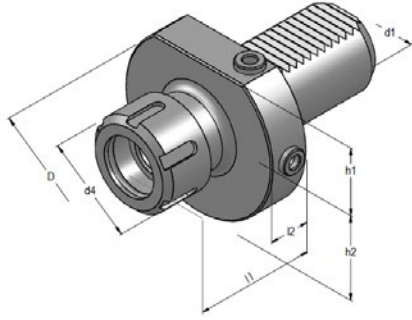

Order No. Bestell-Nr. Sipariş No.	Description Bezeichnung Açıklama	d_1	Capacity Spannbereich Kapasite	D	d_4	h_1	h_2	l_1	l_2
730.02.116	VDI30 E4 30 ER25	30	2-16 (ER 25)	68	42	28	30	57	22
730.02.120	VDI30 E4 30 ER32	30	2-20 (ER 32)	68	50	28	30	75	22
730.02.126	VDI30 E4 30 ER40	30	3-26 (ER 40)	68	63	28	30	75	22
740.02.116	VDI40 E4 40 ER25	40	2-16 (ER 25)	83	42	32,5	-	75	22
740.02.120	VDI40 E4 40 ER32	40	2-20 (ER 32)	83	50	32,5	-	75	22
740.02.126	VDI40 E4 40 ER40	40	3-26 (ER 40)	83	63	32,5	-	75	22



Collet
Spannzange
Pens

128



Clamping Nut
Spannmutter
Kapak

138



Wrench
Spannschlüssel
Ay Anahtarı

142

Adaptor Sleeve for MT, tanged, Form F1

VDI (DIN 69880)



Zwischenhülse für MK mit Austreibblappen Form F1

Mors Konik Adaptörü Form F1

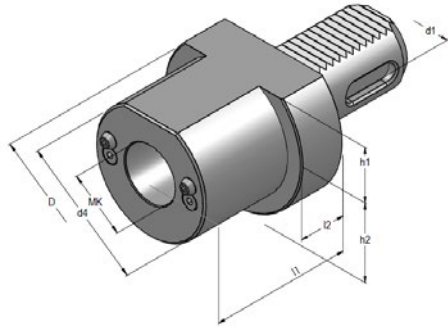

Order No. Bestell-Nr. Sipariş No.	Description Bezeichnung Açıklama	d ₁	MK	d ₄	D	l ₁	l ₂	h ₁	h ₂
730.07.101	VDI30 F1 30xMK1	30	1	-	68	27	-	28	30
730.07.102	VDI30 F1 30xMK2	30	2	-	68	27	-	28	30
730.07.103	VDI30 F1 30xMK3	30	3	58	68	66	22	28	30
740.07.101	VDI40 F1 40xMK1	40	1	55	83	32,5	22	32,5	-
740.07.102	VDI40 F1 40xMK2	40	2	55	83	32,5	22	32,5	-
740.07.103	VDI40 F1 40xMK3	40	3	55	83	32,5	22	32,5	-
740.07.104	VDI40 F1 40xMK4	40	4	68	83	32,5	22	32,5	-

Drill Chuck Adaptor DIN 238

VDI (DIN 69880)



Bohrfutteraufnahme DIN 238

Mandren Malafası DIN 238

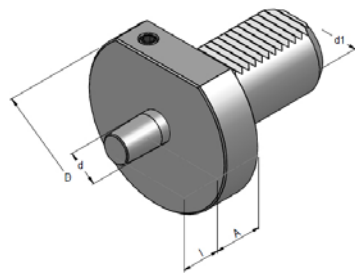

Order No. Bestell-Nr. Sipariş No.	Description Bezeichnung Açıklama	d ₁	d	D	A	l
730.14.116	VDI30 B16	30	B16	68	27	24
740.14.116	VDI40 B16	40	B16	83	27	24



Drill Chuck
Bohrfutter
Mandren

NC-Drill Chuck with Central Coolant

VDI (DIN 69880)



NC-Bohrfutter mit zentraler Kühlmittelzufuhr
NC-Mandren Malafası Merkezden Su Vermeli

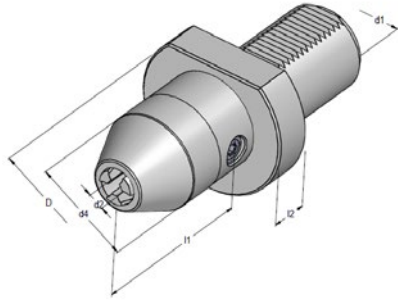

Order No. Bestell-Nr. Sipariş No.	Description Bezeichnung Açıklama	d ₁	Capacity d ₂ Spannbereich Kapasite	d ₄	D	l ₁	l ₂
730.15.113	VDI30 1-13	30	1,0-13	50	68	93	22
730.15.116	VDI30 2,5-16	30	2,5-16	50	68	98	22
740.15.113	VDI40 1-13	40	1,0-13	50	83	93	22
740.15.116	VDI40 2,5-16	40	2,5-16	50	83	98	22

NC-Drill Chuck with Coolant Supply via Spray Nozzles

VDI (DIN 69880)



Bohrfutter mit Kühlmittelzufuhr über Kugelspritzdüsen
NC-Mandren Malafası Alından Soğutma Suyu Vermeli

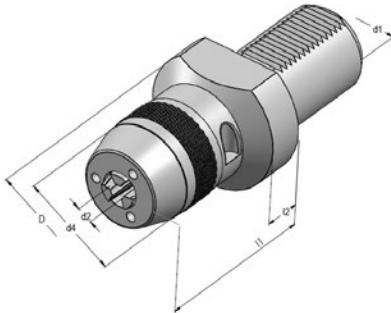

Order No. Bestell-Nr. Sipariş No.	Description Bezeichnung Açıklama	d ₁	Capacity d ₂ Spannbereich Kapasite	d ₄	D	l ₁	l ₂
730.15.213	VDI30 1-13	30	1,0-13	50	68	87	22
730.15.216	VDI30 2,5-16	30	2,5-16	55	68	93	22
740.15.213	VDI40 1-13	40	1,0-13	50	83	88	22
740.15.216	VDI40 2,5-16	40	2,5-16	55	83	93	22

Quick Change Tapping Chuck with Compensation

VDI (DIN 69880)



Gewindeschneidfutter mit Längenausgleich
Kılavuz Çekme Başlığı Giriş-Çıkış Kompanzeli

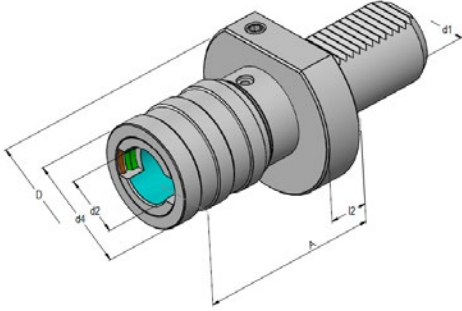

Order No. Bestell-Nr. Sipariş No.	Description Bezeichnung Açıklama	d ₁	Capacity Spannbereich Kapasite	D	A	d ₄	d ₂	C	T
730.16.112	VDI30 M3-M12	30	M3-M14	68	55	38	19	9	9
730.16.120	VDI30 M5-M24	30	M5-M24	83	77	55	31	15	15
740.16.112	VDI40 M3-M12	40	M3-M14	68	55	38	19	9	9
740.16.120	VDI40 M5-M24	40	M5-M24	83	77	55	31	15	15

Protective Plug Z2 Plastic

VDI (DIN 69880)



Schutzstopfen Z2 Kunststoff
Plastik Kör Tapa Z2

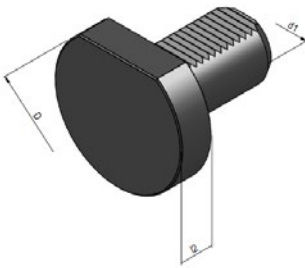

Order No. Bestell-Nr. Sipariş No.	Description Bezeichnung Açıklama	d ₁	D	L2
730.28.120	VDI30 Z2 30x20	30	68	16
740.28.120	VDI40 Z2 40x20	40	83	20



Tapping Collet
Einsatz
Kılavuz Tutucu

144