

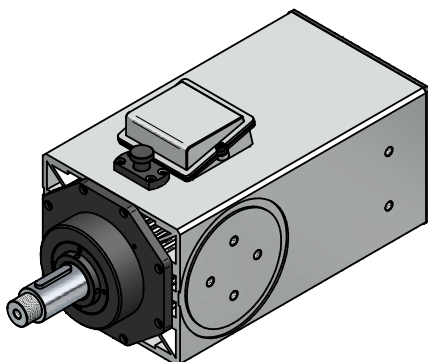

TYPE	VOLTAGE [Volt]	FREQUENCY [Hz]	RPM	DELIVER POWER [Kw]	ABSOR. [Amp]	Cos j	WEIGHT [Kg]
PE7 11/2	220/380	50	3000	4,0	15,7/9,1	0,82	38
	380Δ	100	6000	5,8	12,9Δ		
PE7 15/2	220/380	50	3000	5,6	20,2/11,7	0,80	45
	380Δ	100	6000	8,2	17,7Δ		
PE7 17/2	220/380	50	3000	6,2	24,0/13,8	0,80	50
	380Δ	100	6000	8,8	19,6Δ		

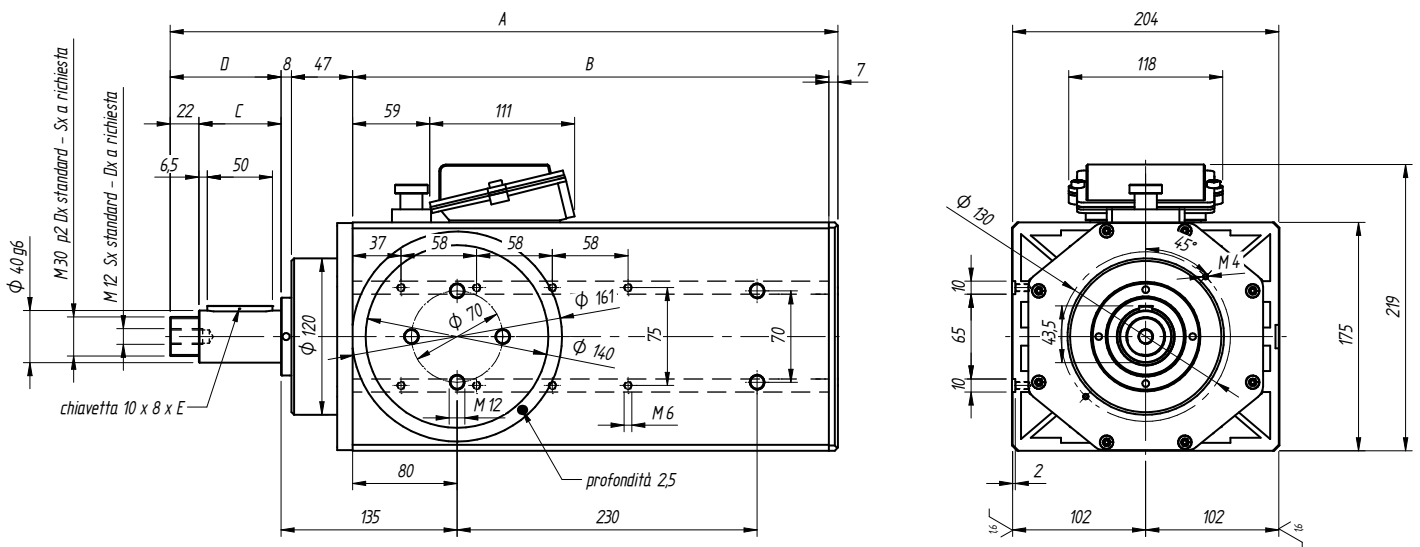

TIPO	A	B	C	D	E
PE7 11/2	512	365	63	85	50
PE7 11/2	542	365	93	115	80
PE7 11/2	567	365	118	140	100
PE7 15/2	512	365	63	85	50
PE7 15/2	542	365	93	115	80
PE7 15/2	567	365	118	140	100
PE7 17/2	562	415	63	85	50
PE7 17/2	592	415	93	115	80
PE7 17/2	617	415	118	140	100

