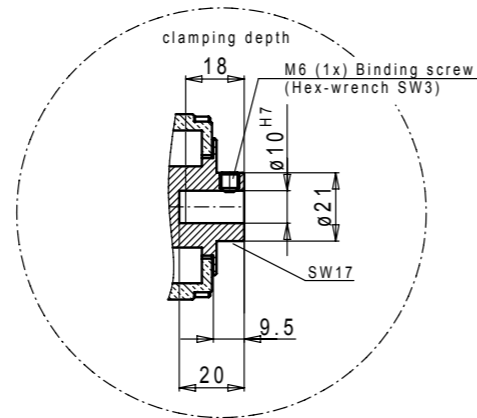
Shank receptacle  $\varnothing 10H7$ **Technical features**

Item Id.	EP-030830
drive turning direction	R.H./L.H.
drive speed max.	permanent operation 1.000 – 14.400 rpm interval operation 1.000 – 18.000 rpm
number of spindles	2
spindle position	max. 10° tilted up or down
tool receptacle	2x $\varnothing 10 H7$ with Binding screw
gear ratio	1 : 1 – wheel drive
turning direction of tool receptacle	opposite to drive turning direction
spindle speed max.	permanent operation 1.000 – 14.400 rpm interval operation 1.000 – 18.000 rpm
drive capacity	3,0 kW
weight without drive adapter	approx. 2,00 kg

**Optional accessories:**

Open end spanner SW 17

Item Id. 131017

Hex- wrench SW3

Item Id. 138030

Lubrication press

Item Id. 980003

The angular heads of the series G07 offer you the possibility to choose an angular head with a fixed spindle position between 10° bended up and up to 10° bended down. In the two-spindle-execution the 180° opposite tool receptacle may have an other angle than the other tool receptacle. The determined angle cannot be modified afterwards. The spindle turning direction is opposite to the drive turning direction. The drive speed is transferred to the tool receptacles in a ratio of 1:1. The maximum spindle speed in interval operation is 18,000 rpm.

The Item Id. EP-030830 denominates the angular drilling head W07-2.2-B only, but does not determine a specific spindle position. It is necessary in case of an order to indicate the requested angle of the drilling spindle in addition to the Item Id. Corresponding to your order you will receive the final Item Id. within the order confirmation for the angular drilling head you ordered. This Item Id. than applies for this specific configuration and can be used in case of further orders without additional information.

**Note:** In case of equipment with drilling receptacles M10 plane the drive turning direction has to be determined before placing the order.

**Variants on demand!**

