

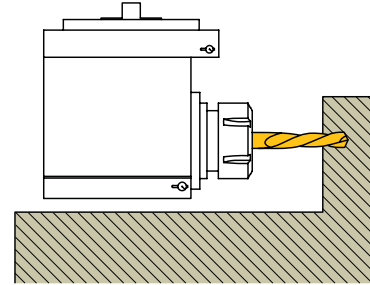

GA-F



GA-F

Suitable for all machine types by using a connection kit  
Verwendbar mit allen Maschinentypen mithilfe einer Anschlusschnittstelle

SK30, SK40, SK50, BT30, BT40, BT50, HSK63A, HSK100A  
Transfer Machines / Transferanlagen



GA-FX

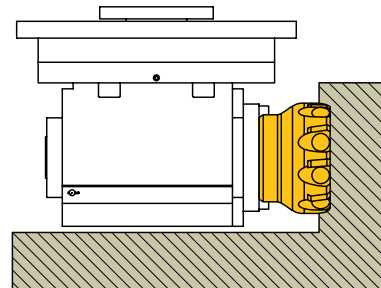

### Features

For drilling, tapping and milling operations  
Used with a flange interface with the spindle for manual loading  
Heat-treated aluminium or steel main body  
Compact and rigid construction

### Merkmale

Für Bohrungen, Gewindebohren und Fräsbearbeitungen  
Flanschverbindung mit der Spindel; manueller Wechsel  
Hauptkörper aus wärmebehandelter Aluminium- oder Stahllegierung  
Kompakte und rigide Bauform

GA-F

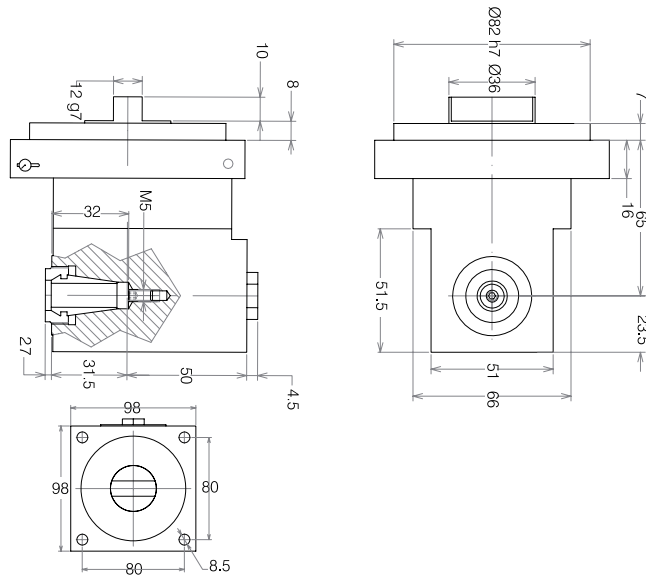

**GA-F16**

ER16	6.000 RPM	24 Nm
------	-----------	-------

Schubkraft Thrust	Gewicht Weight	Übersetzung Ratio
700 N	2 kg	1:1

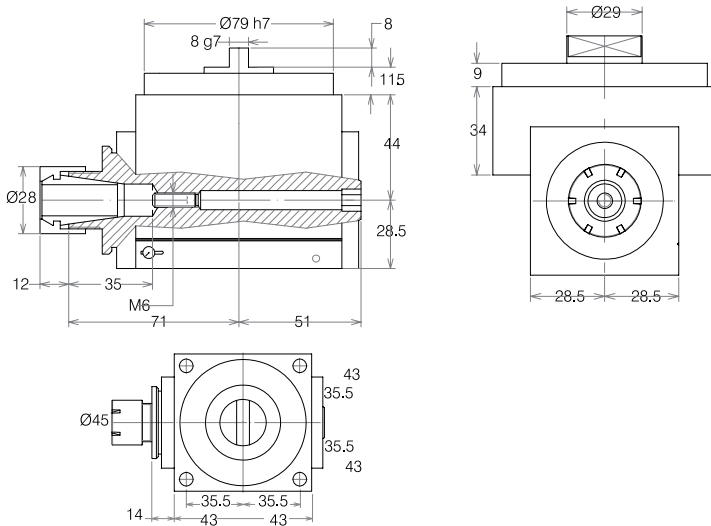

**GA-F20**

ER20	3.000 RPM	24 Nm
------	-----------	-------

Schubkraft Thrust	Gewicht Weight	Übersetzung Ratio
1400 N	2,4 kg	1:1

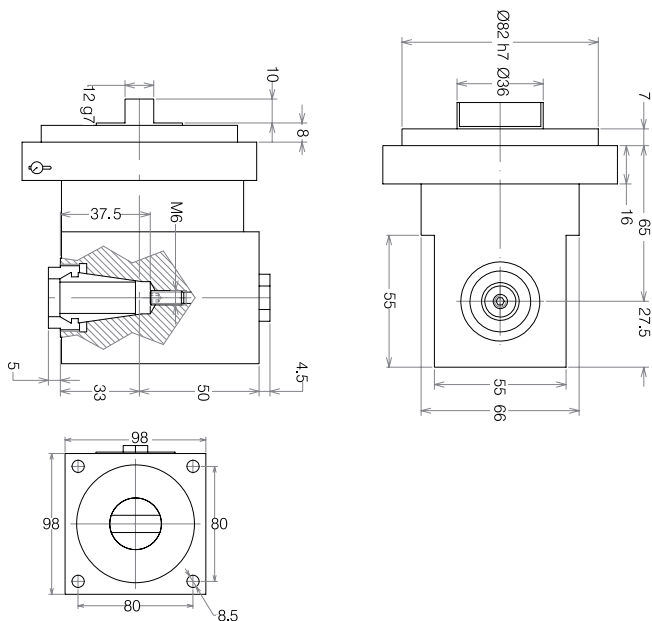

**GA-F20-s**

ER20	6.000 RPM	24 Nm
------	-----------	-------

Schubkraft Thrust	Gewicht Weight	Übersetzung Ratio
700 N	2 kg	1:1

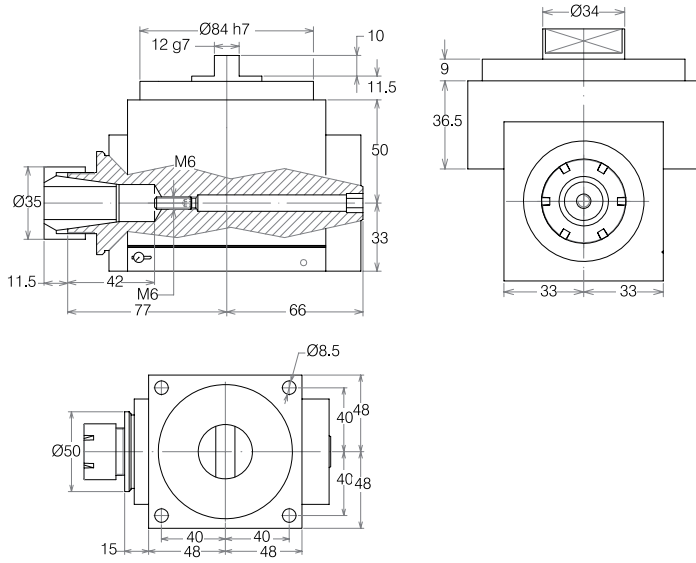

### GA-F25

ER25	3.000 RPM	24 Nm
------	-----------	-------

Schubkraft Thrust	Gewicht Weight	Übersetzung Ratio
1400 N	3 kg	1:1

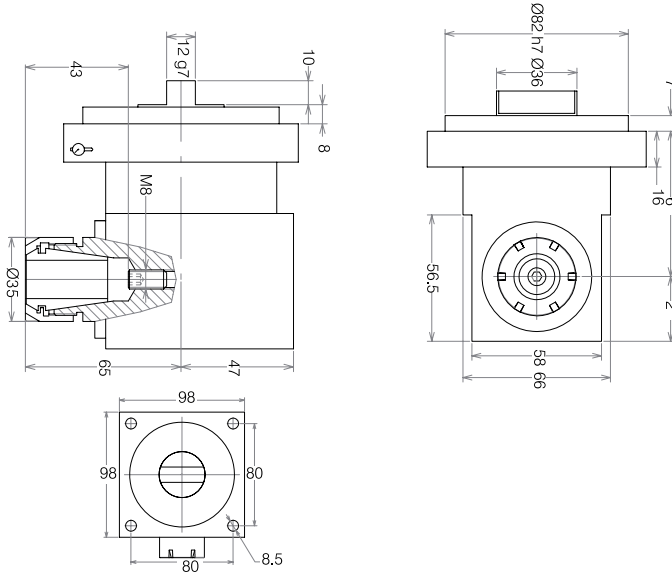

### GA-F25-s

ER25	6.000 RPM	24 Nm
------	-----------	-------

Schubkraft Thrust	Gewicht Weight	Übersetzung Ratio
1000 N	2.3 kg	1:1

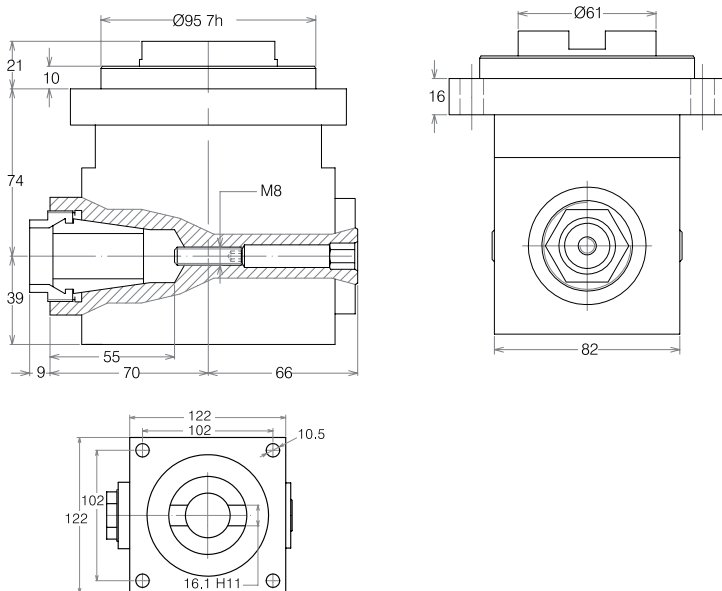

### GA-F32

ER32	3.000 RPM	55 Nm
------	-----------	-------

Schubkraft Thrust	Gewicht Weight	Übersetzung Ratio
1500 N	7,7 kg	1:1

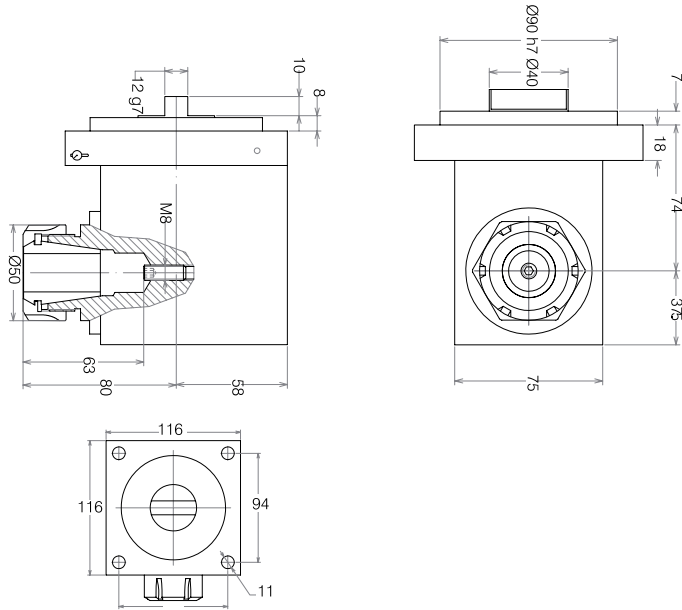

### GA-F32-s

ER32	6.000 RPM	30 Nm
------	-----------	-------

Schubkraft Thrust	Gewicht Weight	Übersetzung Ratio
2200 N	4 kg	1:1

## GA-FX

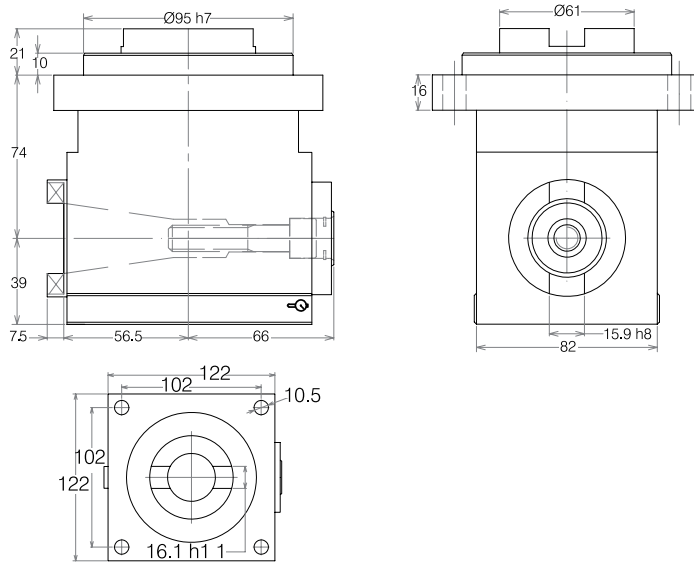

### GA-FX30

ISO30	3.000 RPM	46 Nm
-------	-----------	-------

Schubkraft Thrust	Gewicht Weight	Übersetzung Ratio
1500 N	7,7 kg	1:1

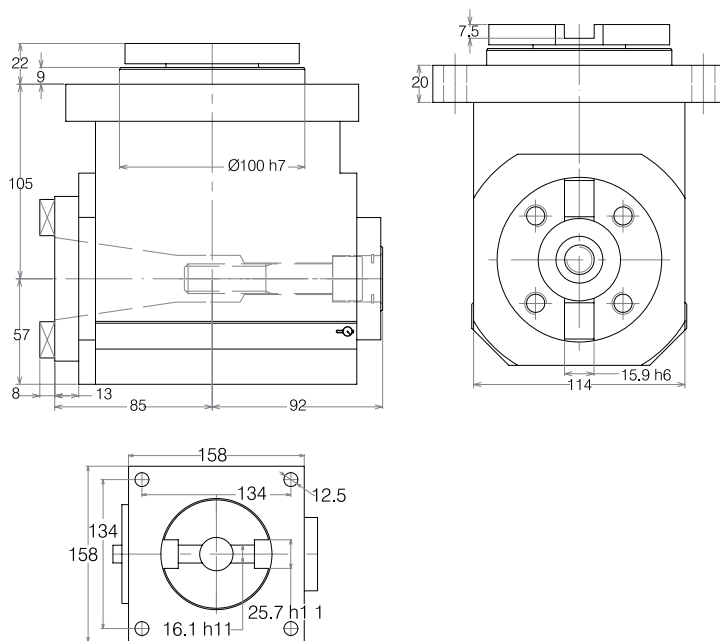

### GA-FX40

ISO40	2.000 RPM	120 Nm
-------	-----------	--------

Schubkraft Thrust	Gewicht Weight	Übersetzung Ratio
3000 N	22 kg	1.5 : 1

### GA-FX40 ROTATE

ISO40 2.000 RPM 120 Nm

Schubkraft Thrust	Gewicht Weight	Übersetzung Ratio
3000 N	26 kg	1.5 : 1

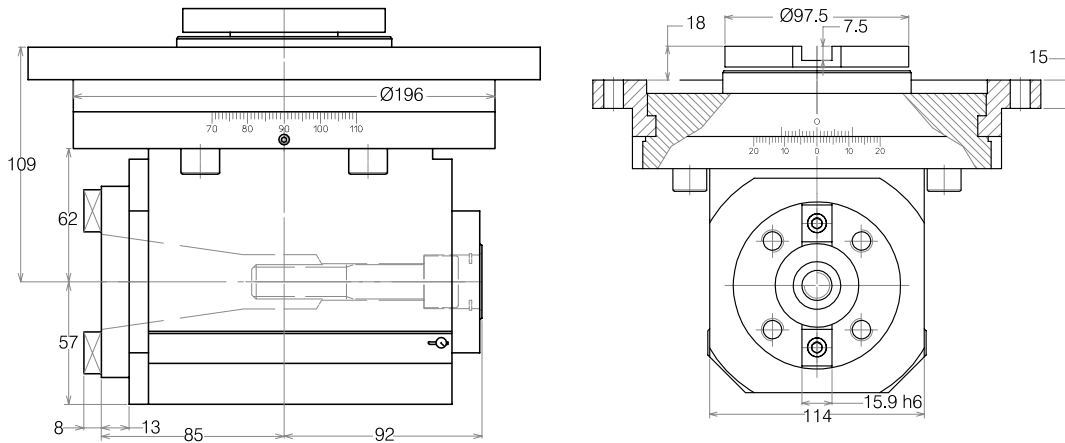

**GA-FX**

### GA-FX50

ISO50 3.000 RPM 390 Nm

Schubkraft Thrust	Gewicht Weight	Übersetzung Ratio
3000 N	40 kg	1:1

