

HiL 150 LC



HiL 150 LC

(cambio utensile automatico)

Fresatura e foratura di pannelli in massello e profilati in alluminio. Lavorazione di modelli in resina e compositi. Incisione di bassorilievi e targhe.

HiL 150 LC

(automatic tool change)

Milling and drilling of solid wood panels or aluminium profiles. Milling of resin and composite moulds. Bas-reliefs and plates engraving.

HiL 150 LC

(automatischer Werkzeugwechsel)

Fräsarbeiten von starken Kernholztafeln, modelieren von Fensterrahmen und Wölbungen. Planarbeit und Trimmen von Kernholztafeln.

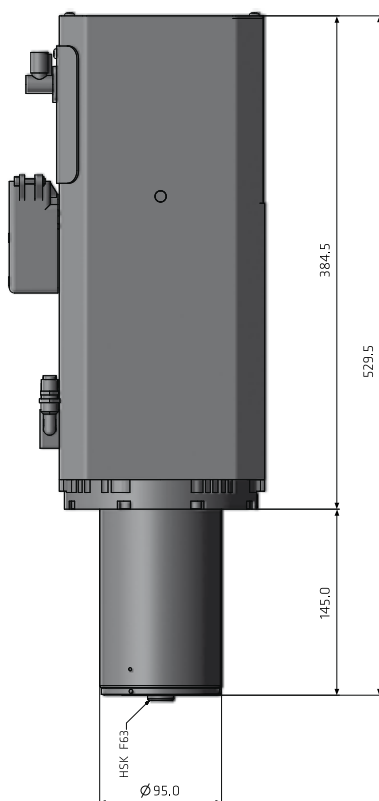
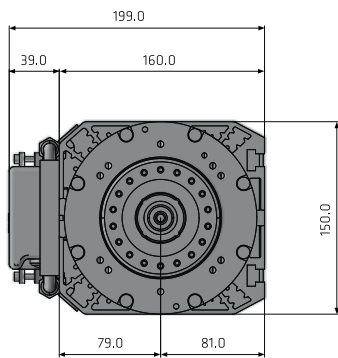

Potenza Power Leistung

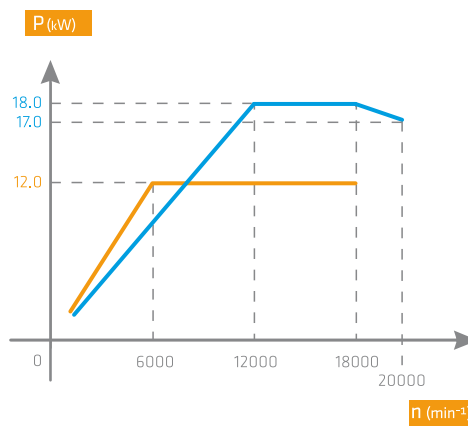

Coppia Moment Torque Drehmoment

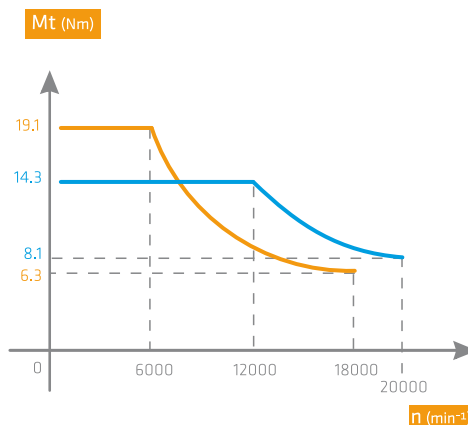

Tipo Elettromandrino Type of Electrospindle Elektrospindeltyp	HiL 150 LC
Potenza (kW) Power (kW) Leistung	12/18
Coppia (Nm) Torque (Nm) Drehmoment (Nm)	19,1/14,3
Velocità massima n(min-1) Cuscinetti ceramici Max speed n(min-1) Hybrid ball bearings Max Drehzahl n(min-1) Kegellager mit Keramikugeln	18000/20000
Attacco utensile Tool Taper Werkzeugaufnahme	HSK F 63
Raffreddamento motore Motor Cooling Motorkühlung	Liquido Liquid Flüssig