

# COMPACT 115 LC

LONG NOSE



## COMPACT 115 LC

(cambio utensile automatico)

Per la fresatura ad alta velocità dei modelli in resina o alluminio, lavorazione su acetati, fresature e finitura di stampi e punzoni.

## COMPACT 115 LC

(automatic tool change)

High-speed milling of resin or aluminium moulds, acetate plastic shaping, milling and finishing of die-cast.

## COMPACT 115 LC

(automatischer Werkzeugwechsel)

Hochgeschwindigkeitsfräsen für Kunststoff- und Aluminiummodelle, Bearbeitung von Azetaten, Fräsen bzw. Fertigbearbeitung von Modellen und Stempeln.

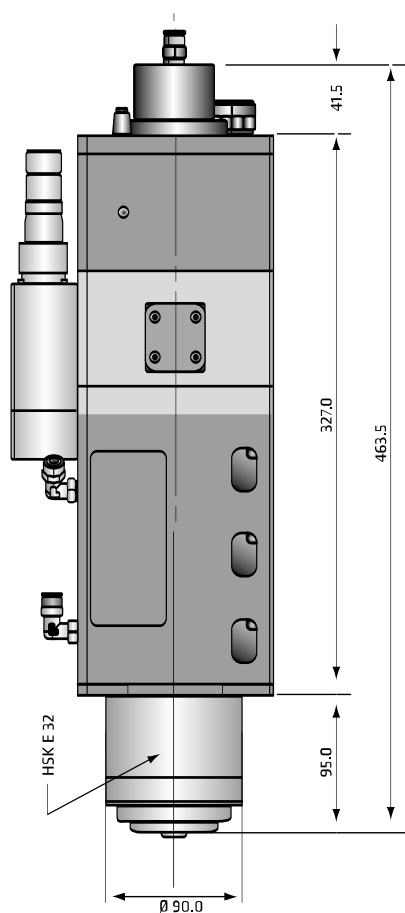
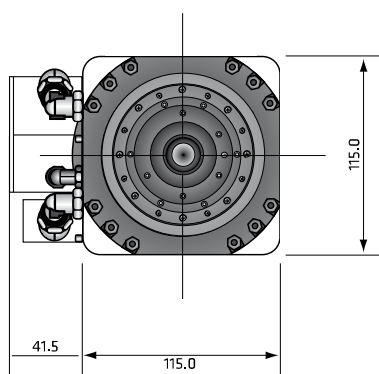

### Potenza Power Leistung

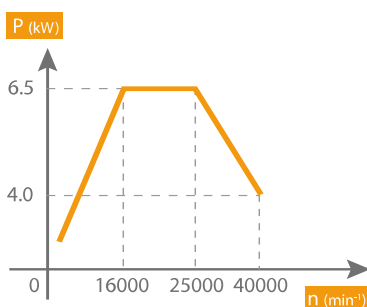

### Coppia Torque Drehmoment

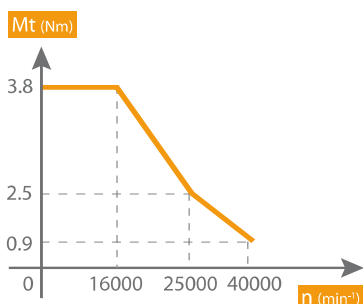

Tipo Elettromandrino Type of Electrospindle Elektrospindeltyp	<b>Compact 115 LC</b>
Potenza (kW) Power (kW) Leistung	<b>6,5</b>
Coppia (Nm) Torque (Nm) Drehmoment (Nm)	<b>3,8</b>
Velocità massima n(min <sup>-1</sup> ) Cuscinetti ceramici Max speed n(min <sup>-1</sup> ) Hybrid ball bearings Max Drehzahl n(min <sup>-1</sup> ) Kegellager mit Keramikugeln	<b>32000</b>
Velocità massima n(min <sup>-1</sup> ) Cuscinetti in Cronidur Max speed n(min <sup>-1</sup> ) Cronidur ball bearings Max Drehzahl n(min <sup>-1</sup> ) Cronidur-Kugellager	<b>40000</b>
Attacco utensile Tool Taper Werkzeugaufnahme	<b>HSK E 32</b>
Raffreddamento motore Motor Cooling Motorkühlung	<b>Liquido Liquid Flüssig</b>