



High speed precision spindles

SCHEDA TECNICA

PE6 SQUADRATICI SF



MODELLO	TENSIONE [Volt]	FREQUENZA [Hz]	GIRI	POT. RESA [Kw]	ASSORB. [Amp]	Cos j	PESO [Kg]
PE6 11/2	220/380 380Δ	50 100	3000 6000	2,3 4,0	9,5/5,5 9,1Δ	0,82	22
PE6 15/2	220/380 380Δ	50 100	3000 6000	3,4 5,6	13,6/7,8 11,5Δ	0,83	30

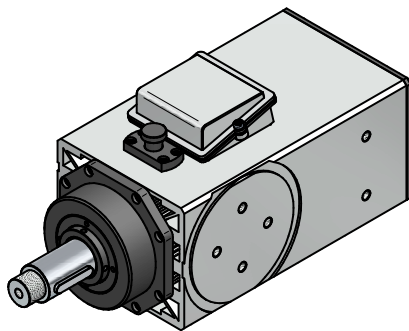
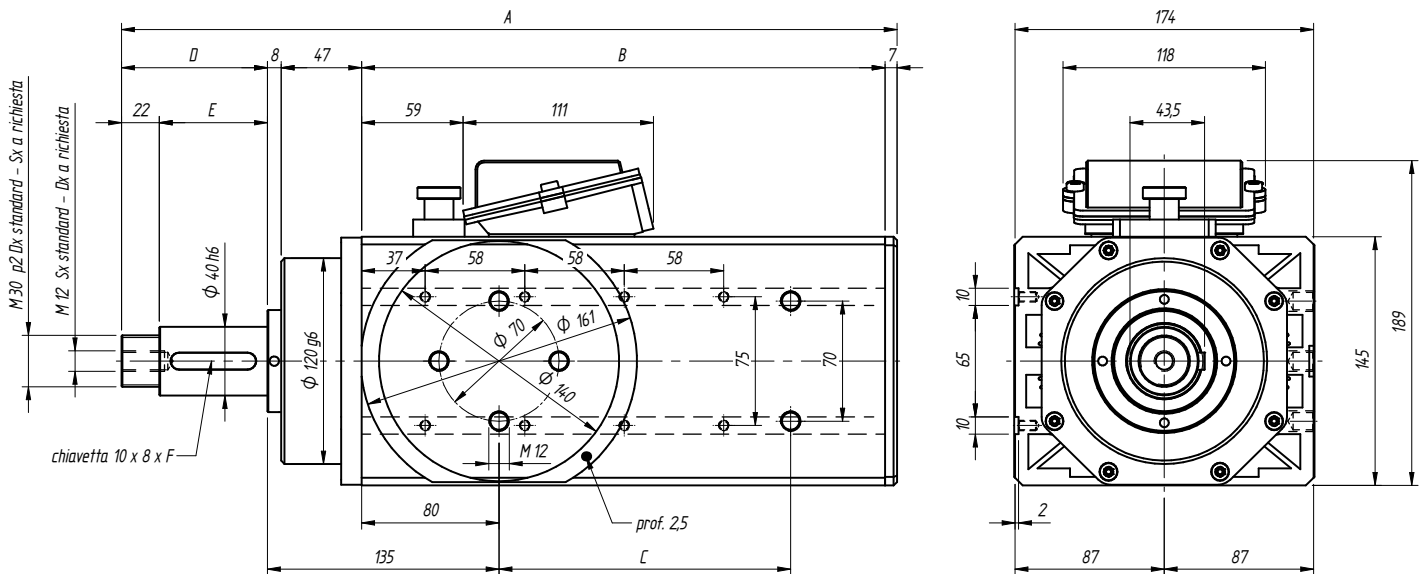

TIPO	A	B	C	D	E	F
PE6 11/2	452	305	170	85	63	50
PE6 11/2	482	305	170	115	93	80
PE6 11/2	507	305	170	140	118	100
PE6 15/2	495	348	230	85	63	50
PE6 15/2	525	348	230	115	93	80
PE6 15/2	550	348	230	140	118	100

