

TF2 CARDANIC



TF2 CARDANIC

Caratteristiche assi

Campo lavoro asse "A"	320°
Campo lavoro asse "C"	640°
Coppia all'asse "A"	300 Nm
Coppia all'asse "C"	400 Nm
Velocità rapido	27 rpm

TF2 CARDANIC

Continuous rotation specifications

Axis range "A"	320°
Axis range "C"	640°
Axis rated torque "A"	300 Nm
Axis rated torque "C"	400 Nm
Positioning speed	27 rpm

TF2 CARDANIC

Eigenschaften Dauerachsen

Durchlauf Achse "A"	320°
Durchlauf Achse "C"	640°
Drehmoment Achsen "A"	300 Nm
Drehmoment Achsen "C"	400 Nm
Positionierungsgeschwindigkeit	27 rpm

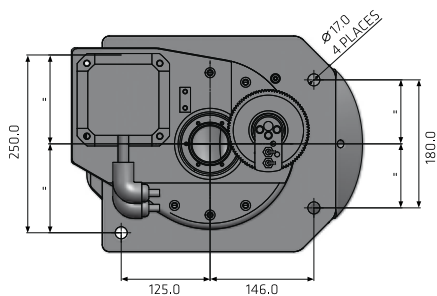
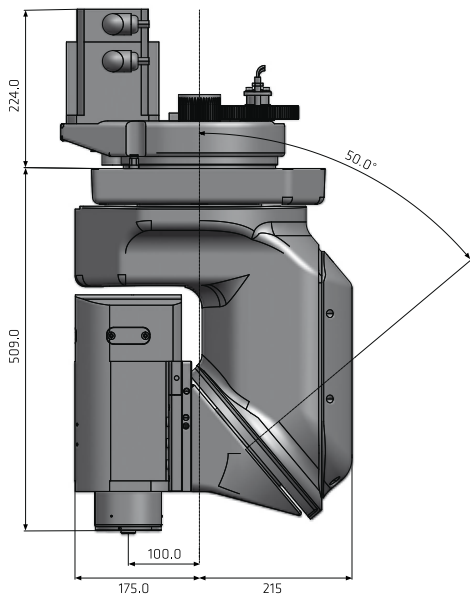

Potenza Power Leistung

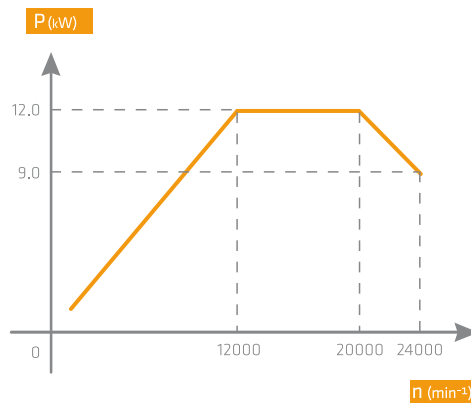

Coppia Moment Torque Drehmoment

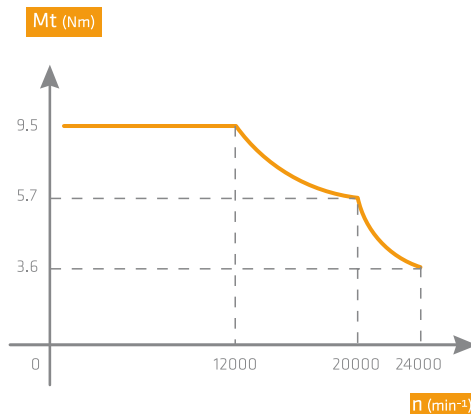

Tipo Elettromandrino Type of Electrospindle Elektrospindeltyp	TF2 CARDANIC
Potenza (kW) Power (kW) Leistung	12
Coppia (Nm) Torque (Nm) Drehmoment (Nm)	9.5
Velocità massima n (min ⁻¹) Cuscinetti ceramici Max speed n (min ⁻¹) Ceramic ball bearings	24000
Max Drehzahl n (min ⁻¹) Kegellager mit Keramikugeln	
Attacco utensile Tool Taper Werkzeugaufnahme	HSK F 63

Raffreddamento motore Motor Cooling Motorkühlung	Liquido Liquid Flüssig
--	------------------------------